

Thank you for purchasing our  
**Cresco 20 SW Fertilizer and Salt Spreader**



We're delighted to have you as a customer and are here to help!  
**First off, let's get your product assembled!**

**Scan for video assembly:**

<https://crescospreaders.com/product/spreaders/estate/cresco-20sw>

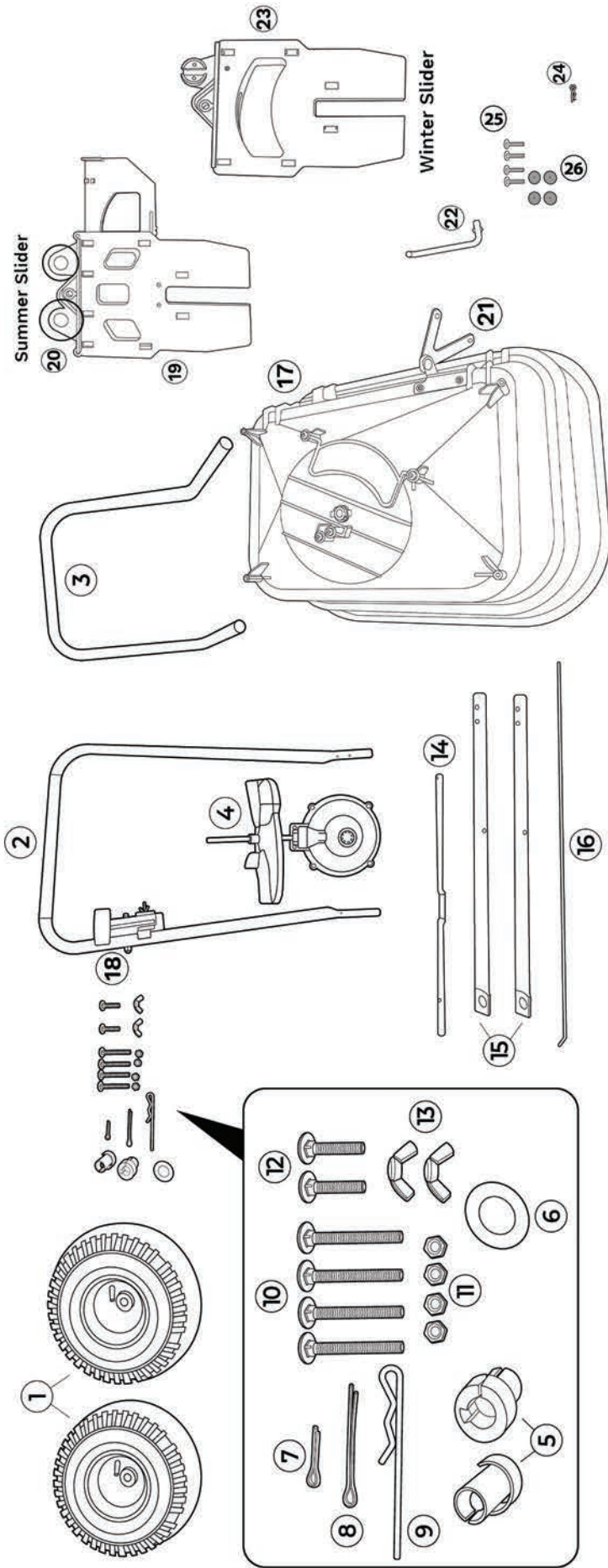

**Table of Contents:**

- 1:** Spare Parts
- 2-5:** Assembling your Cresco20SW
- 6-9:** Slide System Explanation
- 10-13:** How to Use the Cresco20
- 14:** Warranty



# Spare Parts



**Empty all contents of the box onto a flat surface and count parts to make sure all are there.**

## CRESCO 20 PARTS LIST:

1. Pneumatic Wheel (X2) C2004
2. Handle Bar CRP9001
3. Stand C1010
4. Gear box and Impellor C1020 & CRP9005
5. Axle bearing (X2) C1021

6. Wheel Washer CRP9012
7. Small Cotter pin CRP9012
8. Large Cotter pin CRP9012
9. Agitator C1013
10. M6x60 Bolts (X4) CRP9012
11. M6 lock nuts (X4) CRP9012
12. M6 X35 Bolts C1031

13. M6 Wing Nut (X2) C1034
14. Axle C2003
15. Lower Frame (X2) C1008
16. Control Rod C1006
17. Hopper Body CRP9002
18. Control Lever CRP9008

19. Summer Slider CRP9004
20. Adjuster CRP9004
21. Pivot Bracket CRP9002
22. Lower Linkage CRP9012
23. Winter Slider C2001
24. R-pin Small CRP9012
25. 4x Screws
26. 4x Washers

**Scan to view spare parts:**



# Slide System **Explanation**

**Your Cresco spreader comes with two different application sliders.**  
One is for winter and the other is for summer!



**Winter Slider**



**Summer Slider**

**Please locate and choose your slider.**

# Assembling your **Cresco 20**

## ASSEMBLING THE SLIDE SYSTEM, LOWER FRAME AND STAND:

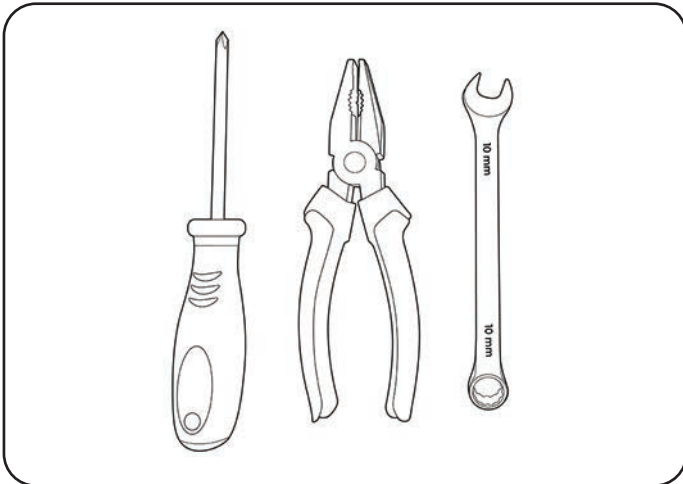

You will need a phillips head screwdriver, one pair of plyers/grips and an M6 metric spanner.

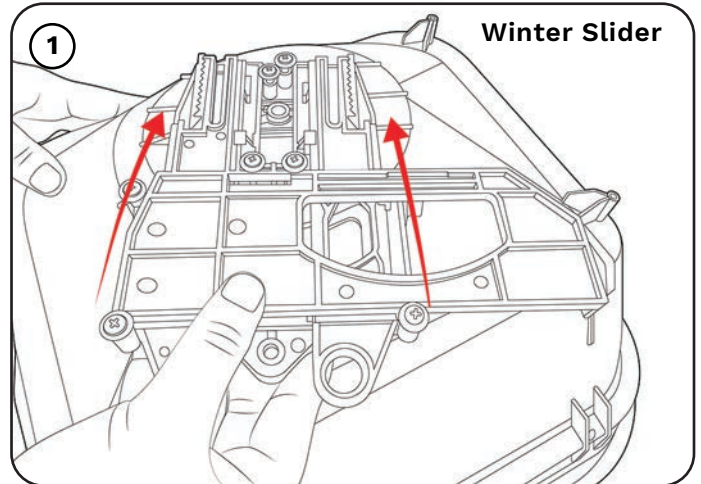

If you are using the spreader for winter, slide the winter application into position as shown above.

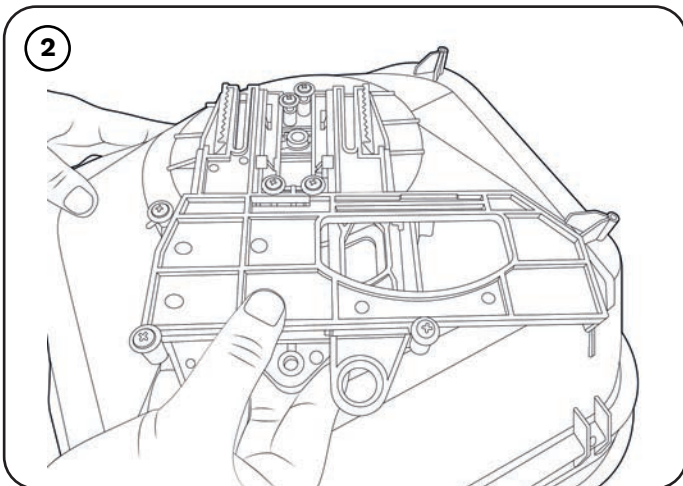

If you are using the spreader for fertiliser or seed, slide the summer application into position as shown above.

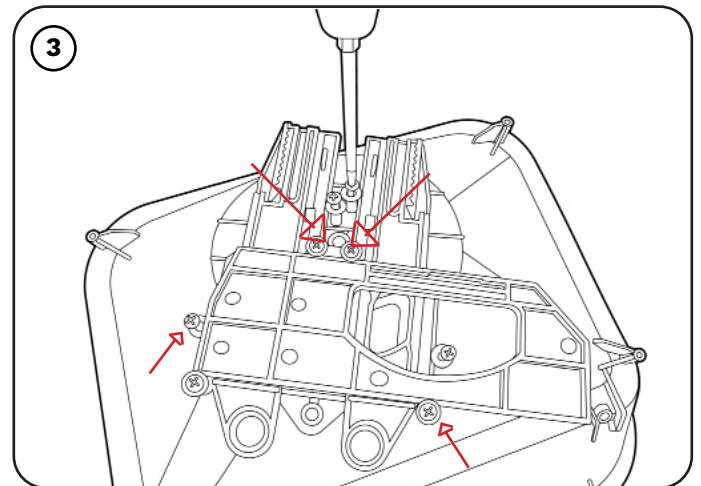

Locate & tighten the 4 screws & washers to fix the required slider (winter or summer) into position. Make sure the screws are not overly tight and the slider can slide backward and forward.

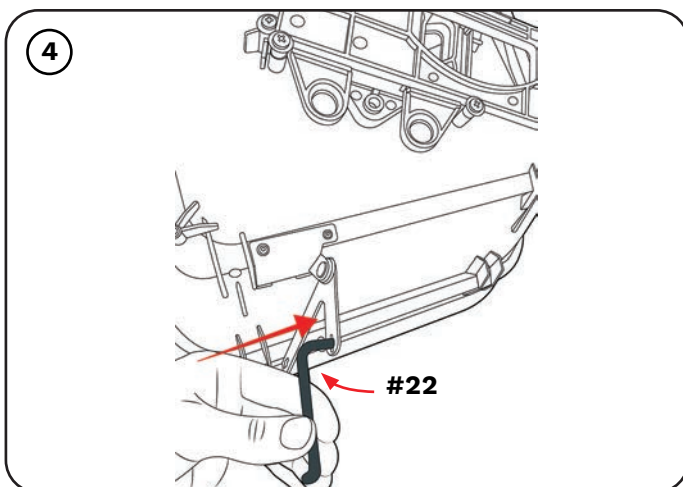

Locate the lower linkage (22) and place it through the pivot bracket (21).

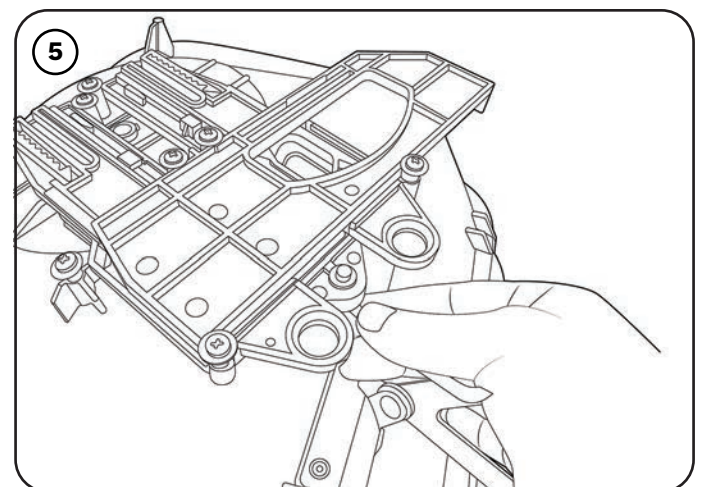

Push the free end of the lower linkage (22) through the centre hole of the chosen slider.

# Assembling your **Cresco 20**

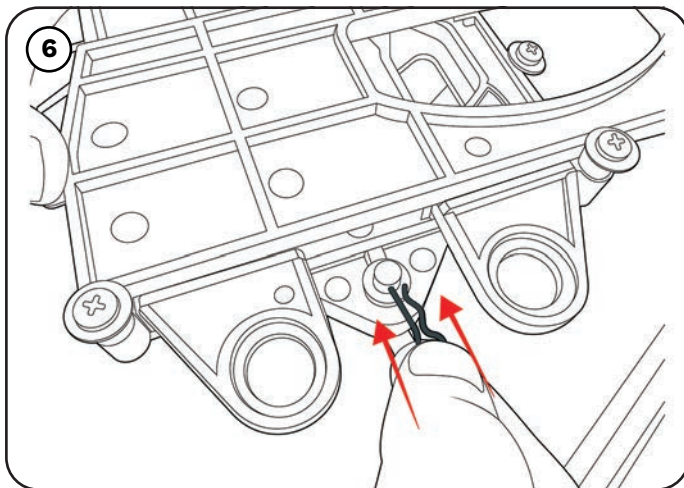

Secure the lower linkage (22) in place using the R pin small as shown.

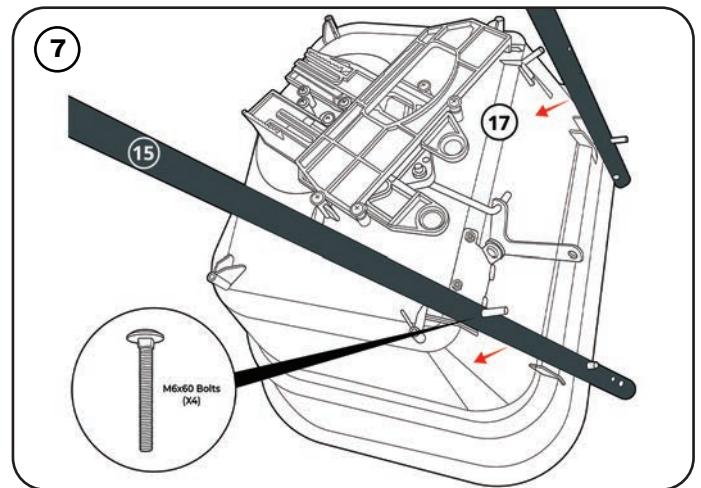

Take the two lower frames (15) and attach them to the hopper body (17) using the M6x60 bolts (10). **SEE NOTE BELOW.** →

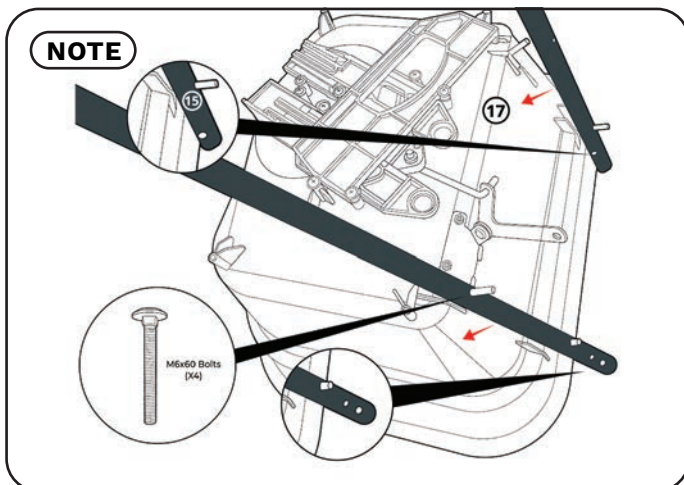

**NOTE**  
When placing the legs on the hopper, make sure the two holes on the side of the lower frame (Item 15) are on the outside. There should be one hole on the inside.

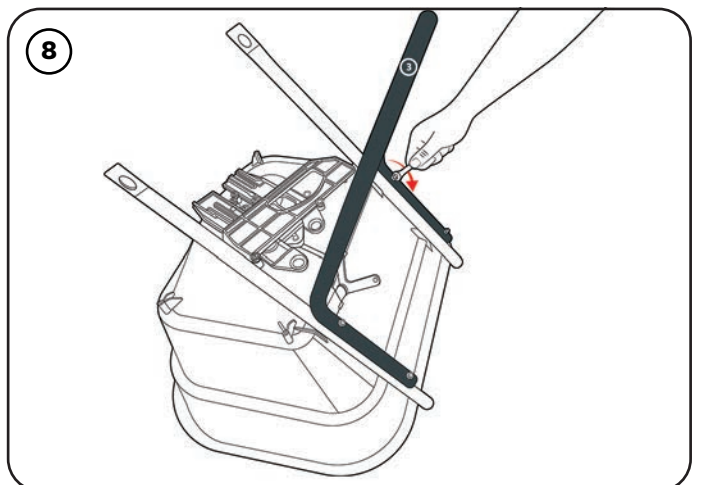

Take the stand (item 3) and place it into the protruding M6x60 bolts (x4) (item 10). Tighten with the M6 lock nuts (x4) (item 11).

## **ASSEMBLING THE WHEELS:**

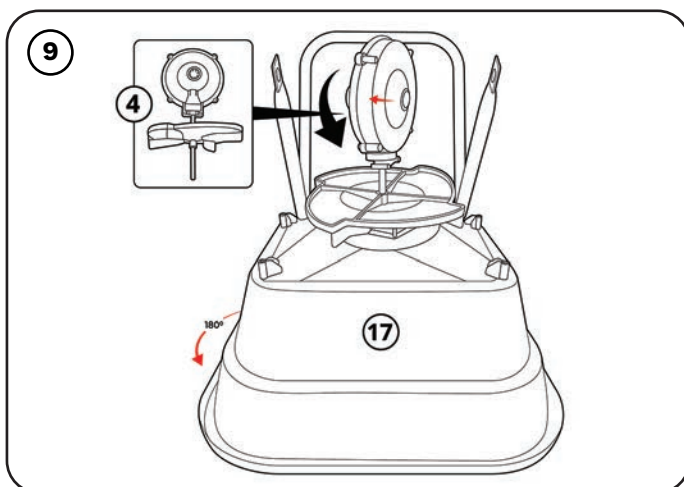

Rotate the hopper body (17) to the position shown. Place the gear box and impeller (4) in the centre hole of the hopper body (17), let it rest there. **Make sure the arrow on the gearbox faces forwards. The arrow should point away from the stand (2).**

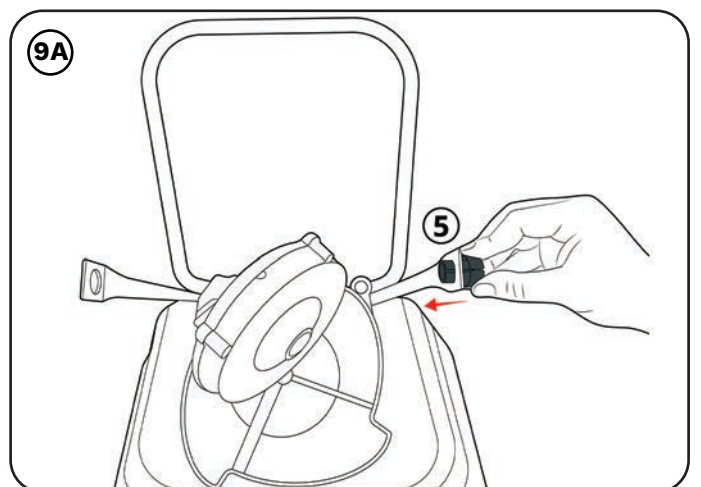

Place one axle bearing (Item 5) into the hole shown at the bottom of the lower frame (15).

## Assembling your **Cresco 20**

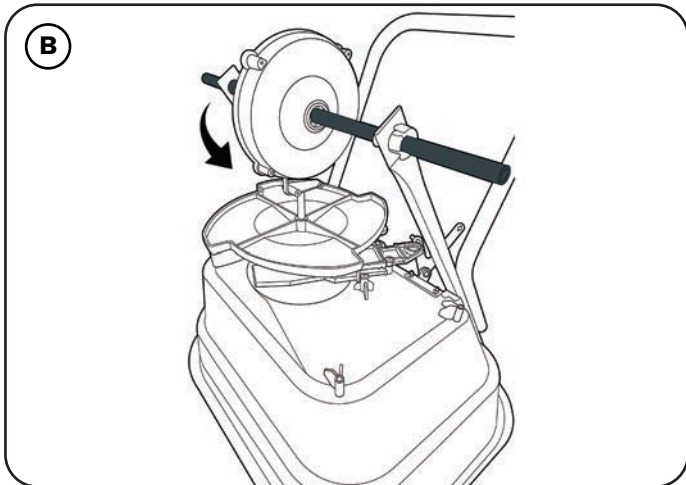

Feed the axle (14) through the hole without the axle bearing (Item 5), push it through the hole in the centre of the gearbox and through the hole (Item 5) on the other side.

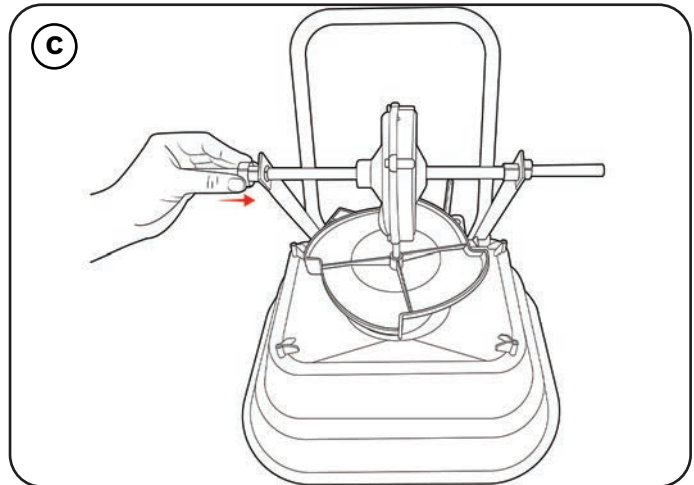

Push the other axle bearing (Item 5) into position.

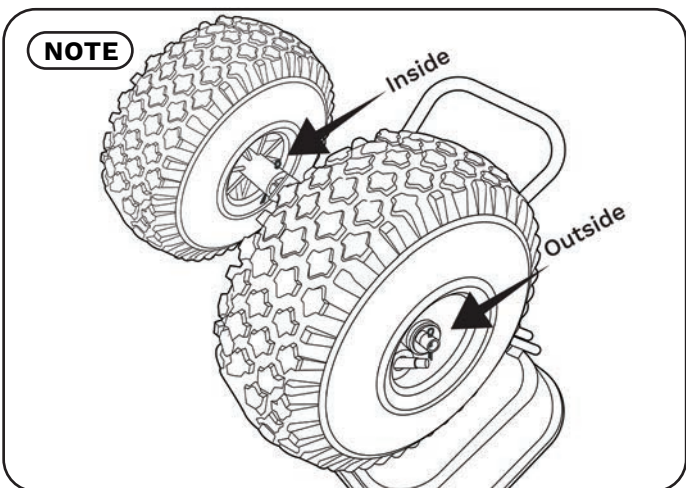

**Note:** The axle and gearbox are now in position. There are two holes on the axle. One hole is closer to the middle of the axle and the other hole is closer to the edge of the axle. When assembling the wheels: one wheel will be pinned on the inside of the wheel and the other will be pinned on the outside of the wheel.

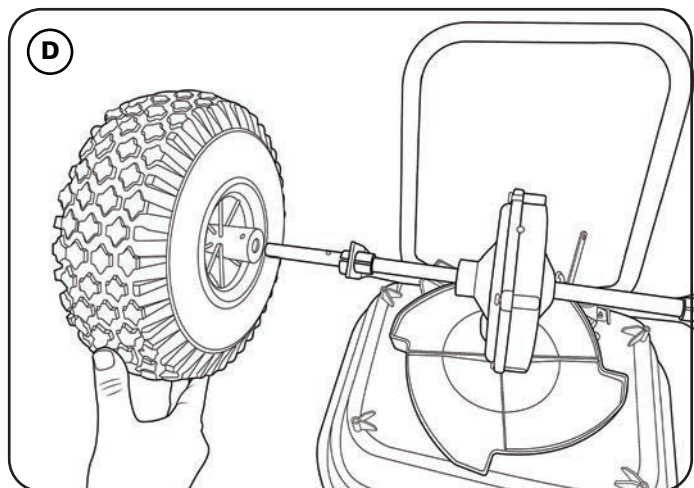

Take one of the pneumatic wheels. Push the wheel through the axle. Make sure the valve is located on the outside.

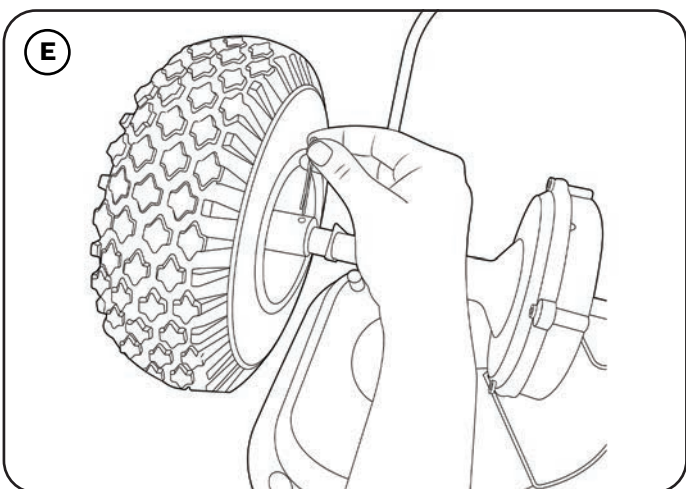

Take the long cotter pin and place it through the hole on the axle on the inside of the wheel.

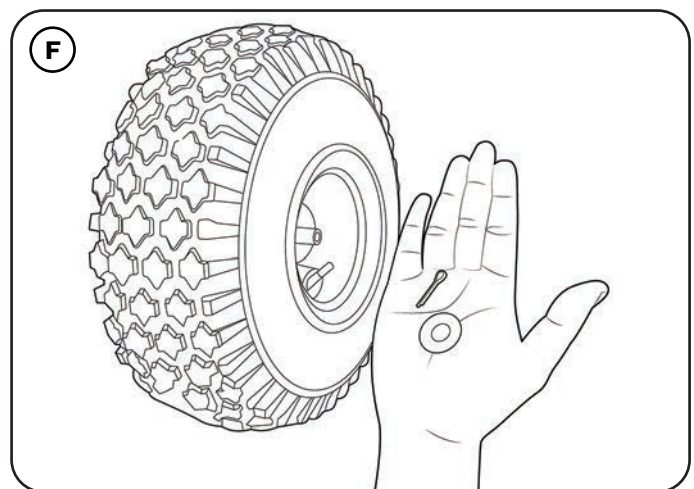

Attach the other pneumatic wheel. Take the small cotter pin (item 7) and the wheel washer (6). Place the wheel washer over the axle and slide the cotter pin (item 7) into the holes to fix the second wheel.

# Assembling your **Cresco 20**

## ASSEMBLING THE HANDLE BAR AND CONTROL ROD:

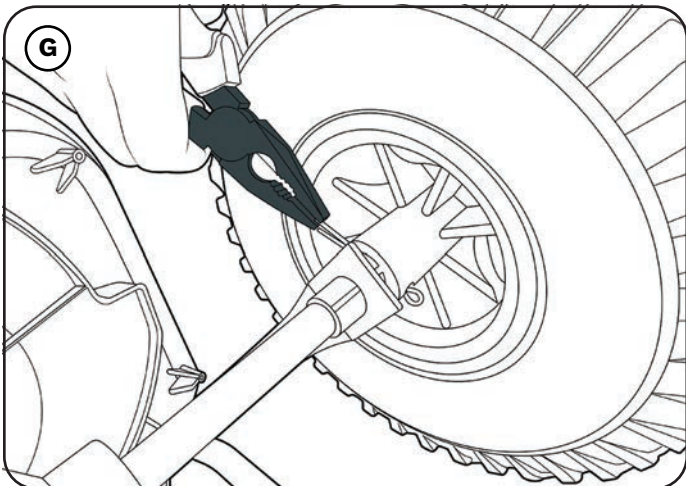

Use the pliers to split the cotter pins on both sides.

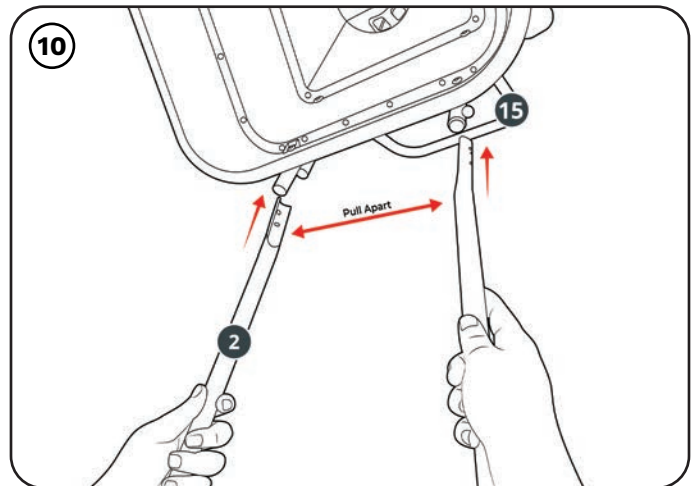

Flip the spreader onto its wheels and ensure they work correctly. Align the holes at the bottom of the handle bar (item 2) with the holes at the top of the lower frame (item 15). You may need to pull the ends apart slightly to place in position.

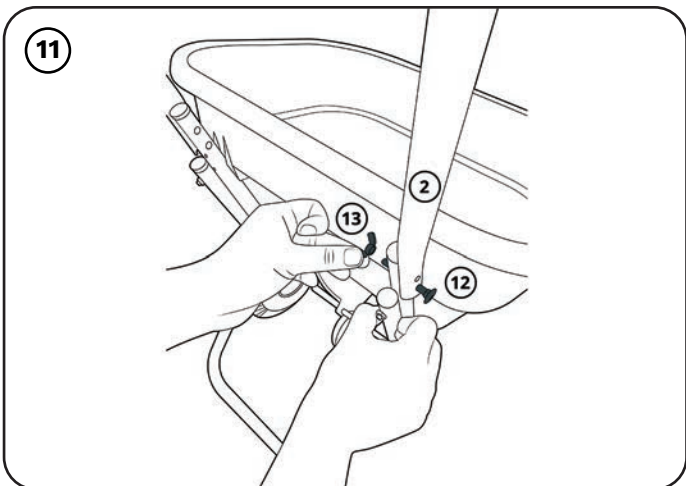

Thread the M6x35 bolt through the hole of the handle bar (item 2) and lower frame (item 15). Use the M6 wingnut to tighten. Repeat on both sides.

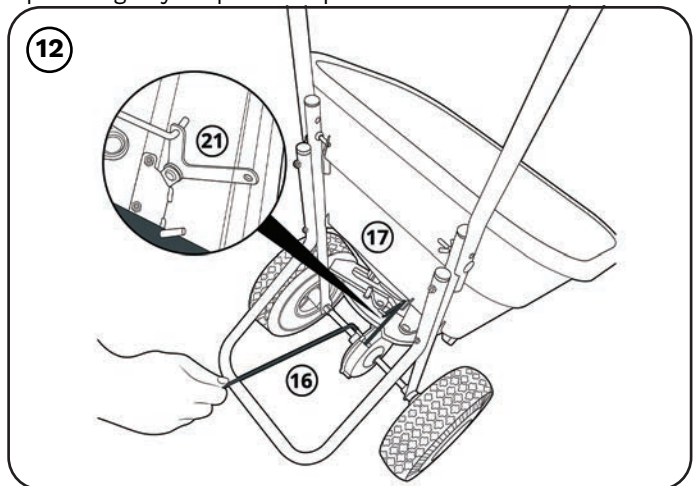

Protruding from the back of the hopper body (item 17) is a V-shaped metal (Item 21-pivot bracket). Clip the L shaped end of the control rod (item 16) into the hole on the V-shaped metal.

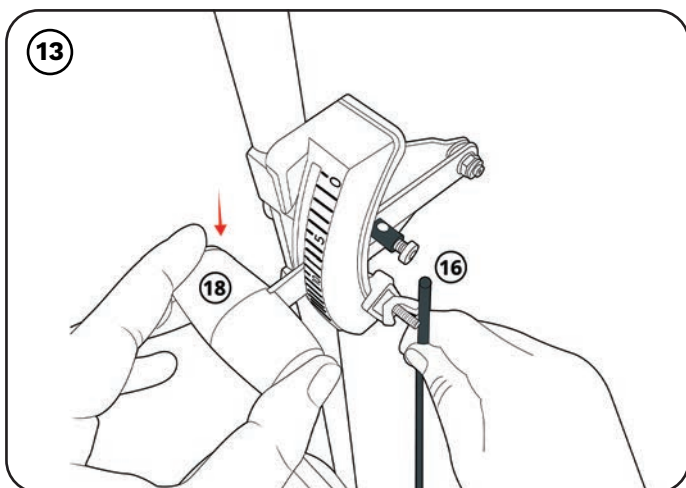

Feed the other end of the control rod (item 16) through the hole at the back of the control lever (item 18). Make sure you push the lever all the way to the bottom.

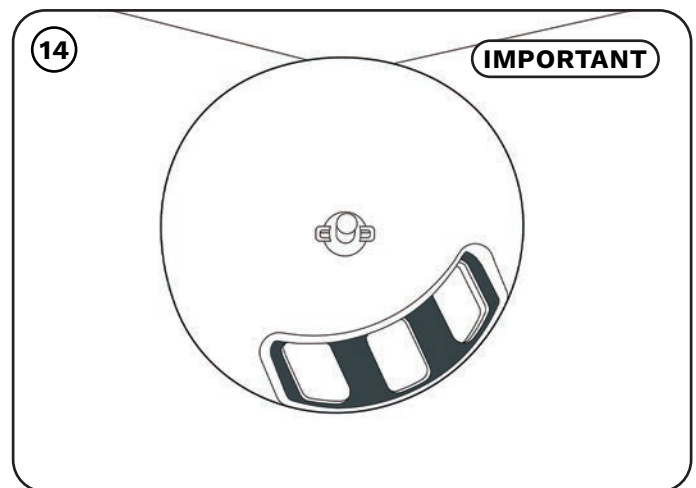

Before tightening the control rod. Make sure the application holes in the hopper are fully open and the control lever is set at 20.

## Assembling your **Cresco 20**

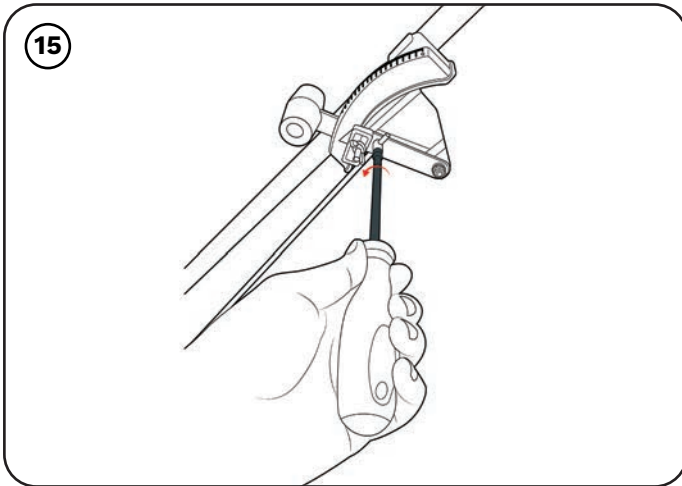

Tighten the control rod.

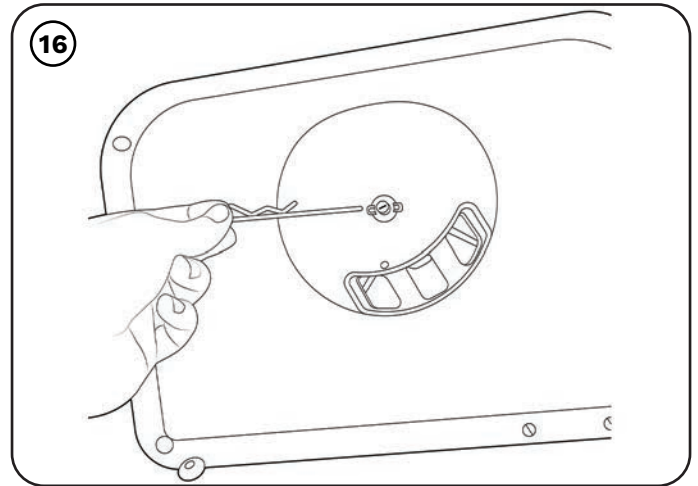

Affix the agitator pin (item 9) through the impeller shaft inside the hopper.



# Slide System **Explanation**

## **Winter**

For maximum spread width up to 6 metres

For reduced pavement setting up to 2 metres



## **Ice Melts**



# Slide System **Explanation**

## **Summer**

The summer slide system comes with 20 different settings and a border control. This provides control over the accuracy of your spreading.

Large/Heavy Materials



Small/Light Materials



## **Border Control**



To protect your borders simply slide the border control into position to cut off the left hand side of the spread pattern.

# Slide System Explanation



SLIDE-SYSTEM  
TECHNOLOGY  
SETTINGS

TWO SEASONS.  
ONE SPREADER.



PRODUCT		SUMMER SLIDER	SLIDER ADJUSTER SETTINGS	
	<b>POWDERED OR MICRO GRANULAR FERTILIZER</b>		<b>NO ADJUSTMENT OF EITHER SLIDER RECOMENDED</b>	
	<b>MEDIUM GRANULAR FERTILIZER</b>		<b>NO ADJUSTMENT OF EITHER SLIDER RECOMENDED</b>	
	<b>LARGE GRANULAR FERTILIZER</b>		<b>ADJUSTMENT OF THE LEFT SLIDER RECOMENDED 6-7 CLICKS</b>	
	<b>GRASS SEED OR VERY LIGHT MATERIALS</b>		<b>ADJUSTMENT OF THE RIGHT SLIDER RECOMENDED 3-4 CLICKS</b>	
	<b>PELLETED MATERIALS</b>		<b>ADJUSTMENT OF THE LEFT SLIDER RECOMENDED (SELECT CLOSED)</b>	
	<b>LARGE GRANULAR ICE MELTS</b>		<b>ADJUSTMENT OF THE LEFT SLIDER RECOMENDED (SELECT CLOSED)</b>	
WINTER SLIDER				
** Please note this chart is a guide only. Due to variations in the spreading characteristics of materials, accurate calibration should be carried out by the operator for each different material being applied. **				
	<b>SHARP SAND</b>		<b>FULL OR REDUCED WIDTH SLIDER OPTION RECOMENDED</b>	
	<b>FLOWABLE SAND / SOIL MIX</b>		<b>FULL SLIDER WIDTH USE RECOMENDED</b>	
	<b>COARSE MARINE SALT</b>		<b>FULL OR REDUCED WIDTH SLIDER OPTION RECOMENDED</b>	
	<b>ROCK SALT</b>		<b>FULL SLIDER WIDTH USE RECOMENDED</b>	
	<b>GRIT MATERIALS</b>		<b>FULL SLIDER WIDTH USE RECOMENDED</b>	

\*\* Please note this chart is a guide only. Due to variations in the spreading characteristics of materials, accurate calibration should be carried out by the operator for each different material being applied. \*\*

[WWW.CRESCOSPREADERS.COM](http://WWW.CRESCOSPREADERS.COM)

DMMP Limited is not responsible for misapplication due to incorrect use or incorrect calibration of Cresco spreaders, and any other DMMP Limited spreader brands. For calibration information please refer to "how to calibrate" section on the Cresco website.



# How to use the **Cresco 20**

## How to Apply Fertilizer to your lawn like a pro in four steps!

**Step 1:** Understanding the application rate and settings

**Step 2:** Preparing the Spreader

**Step 3:** Walking Patterns for the optimum application

**Step 4:** Cleaning & Maintenance

## Step 1: Understand the application rate and settings

### Application Rate Settings

Check the back of the fertilizer bag to find out the recommended G/m<sup>2</sup> and spreader application setting.



If the spreader setting is not on the back of the bag, please get in touch with your fertilizer bag provider.



Set the handle to the correct setting.



If you are unable to find the required Cresco volume setting, please visit, [www.crescospreaders.com](http://www.crescospreaders.com)

# How to use the Cresco 20

## **Spread Pattern Settings**

Once you have the correct application rate, you will need to check that the spread of material is even on both sides of the spread pattern.

To balance the spread pattern for your material, check online or with your fertilizer or seed provider.

For a quick reference, please refer to our guide on the previous page

CRESCO SLIDE-SYSTEM TECHNOLOGY SETTINGS		TWO SEASONS. ONE SPREADER.	
PRODUCT	SUMMER SLIDER	SLIDER ADJUSTER SETTINGS	
 POWDERED OR MICRO GRANULAR FERTILIZER		NO ADJUSTMENT OF EITHER SLIDER RECOMENDED	
 MEDIUM GRANULAR FERTILIZER		NO ADJUSTMENT OF EITHER SLIDER RECOMENDED	

## **Step 2: Preparing the Spreader**

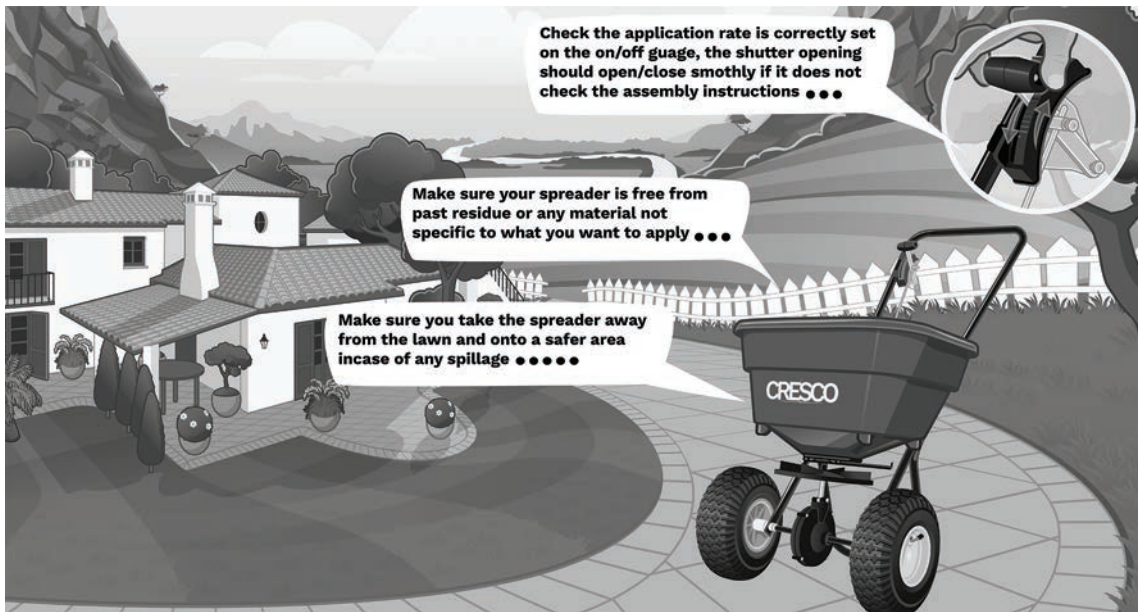

Check the material to be applied is dry and free flowing to ensure it will flow freely through the hopper. Make sure your application rate and spread pattern settings are correct, **close the application hole fully** and then pour in your material.

## How to use the **Cresco 20**

Your outlet hole should look like this you pour in any material.



It is preferable to spread when the weather is dry, however a rain cover can be added to your spreader to ensure the material in your hopper is not exposed to moisture ●●●●●



**WARNING \*\*Do not pour material in the hopper when the application holes are open as it can lead to spillages or leaks that can damage the area. Do not open the gauge until you are over the area you want to spread and are moving at a brisk walk\*\*\***

### **Step 3: Walking Patterns for the optimum application (For Fertilizer Only)**

There are two methods of effective spreading, longitudinal fertilizer spreading and cross sectional fertilizer spreading.

**When applying fertilizer please make sure you walk at 3mph and keep the hopper in a stable, upright position.**

# How to use the Cresco 20

## Longitudinal Fertilizer Spreading

½ the application rate suggested on the back of your fertilizer bag

Cover the area as shown by going over your tire marks left on the previous pass

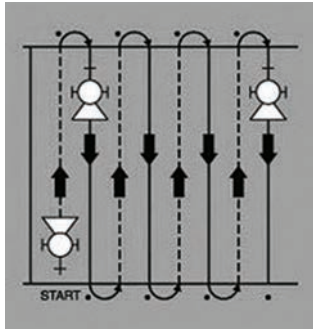

## Cross Sectional Fertilizer Spreading

½ the application rate suggested on the back of your fertilizer bag

Cover the area as shown making the second pass at the edge of your spread pattern or where the fertilizer thrown begins to feather.

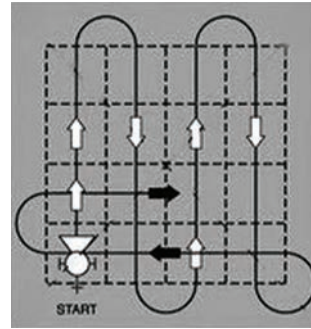

## Step 4: Cleaning and Maintenance

**CLEANING THE SPREADER THOROUGHLY WILL SIGNIFICANTLY ENHANCE THE LIFESPAN OF YOUR SPREADER AND IMPROVE IT'S ABILITY TO SPREAD EVENLY NEXT TIME YOU USE IT.**



## Application guide for **fertilisers**.

LHS (Left hand slider adjuster) is recommended to be engaged when spreading large sized granular materials to provide a more uniform distribution on the left and right side of the spread pattern. Conversely with very light materials (e.g. grass seed) engaging the RHS (Right hand slider adjuster) will be similarly beneficial.

		Speed					
Mph	3						
Kph	4.828						
Metres p/ Sec	1.34						
<b>Calibration Setting Guide</b>							
<b>Product</b>		<b>0.5mm - 1mm</b>		<b>1mm - 2mm</b>		<b>3mm - 5mm</b>	
<b>Width</b>	<b>Metres</b>	3.5	4.0	4.5	3.5	4.0	4.5
<b>Application Rate</b>	<b>Grams / Sq M</b>	20	35	50	20	35	50
<b>Run Time</b>	<b>Secs</b>	10	10	10	10	10	10
<b>Distance</b>	<b>metres</b>	13.4	13.4	13.4	13.4	13.4	13.4
<b>Area</b>	<b>Sq Metres</b>	47	54	60	47	54	60
<b>Target Weight</b>	<b>Grams</b>	938	1,876	3,015	938	1,876	3,015
<b>Setting</b>	<b>Setting</b>	8.5	11	14	11	13.5	19.5
<b>Slider Position</b>	<b>Slider Position</b>	-	-	-	-	-	-
					7 clicks LHS	7 clicks LHS	7 clicks LHS

\*Do not spread Fertiliser or seed materials with the winter slider\*

The manufacturer cannot be held responsible for any variations in sq. metre application volumes, or spread width differences, due to possible variations in materials, application conditions at the time and different operator application techniques.

This chart should be used as a **guide only**.



## 2-Year **Limited Warranty**

DMMP Ltd. warrants this product free of defects in original workmanship and materials for a period of 2 Years to the end user with the original dated purchase receipt.

If a manufacturing non-conformance is found, DMMP Ltd. will repair or replace the part(s) or product at its discretion at no charge provided the failure is not the result of incorrect installation, mishandling, misuse, tampering, or normal wear and tear as determined by DMMP Ltd.

DMMP Ltd. at its discretion may require that the part(s) or product be returned along with the original purchase receipt at owners' expense for examination and compliance with the terms of this warranty.

Do not return any product without first receiving authorization from DMMP Ltd. To seek remedy under this warranty, contact DMMP Ltd. at +44 (0)1455 825 400 or email us at [info@dmmp.co.uk](mailto:info@dmmp.co.uk) and describe the nature of the manufacturing defect.

### **SPECIFIC LIMITATIONS:**

This warranty covers only the part(s) or product; any labour charges associated with repair or replacement of nonconformances are specifically excluded.

Due to the corrosive nature of most fertilizers and ice melt products, DMMP Ltd makes no warranty against and specifically excludes part(s) or product degradation or failure due to corrosion or its effects.

To negate the effects of corrosive materials on your product, clean and dry your spreader or seeder thoroughly after each use. As a further preventative measure, coat all metal parts with a light oil or silicon spray.

